

COSPOLICH

2M
SERIES



R17F13-2M-ADS-MLR

MODEL NUMBERS:

R17F13-2M-ADS-MLR R17F13-2M-SN-MLR MIL SPEC
R13F17-2M-ADS-MLR R13F17-2M-SN-MLR MIL SPEC
R20F20-2M-ADS-MLR R20F20-2M-SN-MLR MIL SPEC

CABINET CONSTRUCTION

Exterior and interior of all standard cabinets, including front, sides, doors and louvered grill are constructed of heavy gauge, type 304 stainless steel.

Special attention was taken in engineering the doors of the Cospolich cabinet. The door unit was designed to withstand the continuous use and abuse that is common in all food service applications.

Resilient vinyl gaskets, which are pre-formed in frames with welded corners, greatly inhibit bacterial growth and are easily replaceable.

Heaters, which are concealed under the thermal breaker strip around the door perimeter, prevent condensation. Interior lighting, a standard item in all refrigerator compartments, is activated by the door opening.

INSTALLATION

As an aid to installation, a foundation for securing the cabinet to the deck is an available option. Installation instructions and a manual are furnished with the unit.

HARDWARE

Positive latches with magnetic back-up are included on all standard cabinets to assure positive latching and sealing. Incorporated into the latch is a replaceable, keyed cylinder lock.

Heavy duty, adjustable, chrome plated hinges are provided on all standard cabinets. Also available, at no extra cost, are 180 degrees self-closing, cam-lift hinges with stay-open feature at 93 degrees.

Cabinet body and doors are insulated with foamed-in-place polyurethane foam, providing for excellent rigidity and the best insulating properties in the industry.

REFRIGERATION SYSTEM

All components of the refrigeration system, with the exception of the evaporator, are bottom mounted on a heavy duty base frame behind a louvered grill which is easily removable without the use of tools. The condensing unit is mounted on a slide out rail for ease in cleaning and servicing.

All evaporator coils are copper tube, and all AC voltage models have forced-air ventilation. The refrigerant flow is monitored by an expansion valve for effective cooling and quick recovery times. A condensate evaporator is provided, thus eliminating the need for additional plumbing.

Temperature of the cabinet is factory adjusted, and the controls, along with an on/off switch are located in the condensing unit area.

Defrost cycles on specified low-temperature cabinets (ADS models) prevent the need for manual defrosting.

SHELVING

Standard interior shelving consists of heavy-duty epoxy-coated steel wire with front rail. Each shelf is adjustable in one-inch increments. Stainless steel shelving and brackets are also available.

SERVICE AID

An optional service kit, including spare parts and installation instructions, is available for each model.

U.L. and U.S.P.H

The equipment is listed by Underwriter's Laboratories, Inc. for safety and sanitation and is built according to standards as set forth by the U.S. Public Health Services.

THIS UNIT AVAILABLE IN OUR SPECIAL MODULAR CONSTRUCTION

OPTIONS

Same options available as offered on the standard construction.

THE MODULAR CONCEPT

This series of modular refrigerators was engineered and constructed to solve the problem of replacing existing failed equipment. Unique to the industry, these units, which comprise a series of interlocking components, brought new meaning to the term "hatchable" equipment. This innovative design allows for equipment upgrades without having to cut access ways in decks and bulkheads or having to modify passage ways.

FEATURES

- Stainless steel interior and exterior (exposed)
- Oversized refrigeration system
- Anti-condensate door heaters
- Heavy-duty chrome-plated hardware
- Automatic activated interior lighting
- Door with adjustable alignment
- Epoxy coated adjustable shelving with front rails
- Removable grill
- Polyurethane insulation
- Slide-out condensing unit
- Resilient gaskets
- Exterior LED thermometer
- Condensate Evaporator Pan
- Auto Defrost

SANITATION
CLASSIFIED
UL
6F42
CLASSIFIED TO
NSF 7 - 1986



www.cospolich.com

Quality & Innovation Since 1937

MODULAR REFRIGERATORS / FREEZERS

MODULAR REFRIGERATORS / FREEZERS

MODEL NUMBERS:

R17F13-2M-ADS-MLR
 R17F13-2M-SN-MLR MIL SPEC
 R13F17-2M-ADS-MLR
 R13F17-2M-SN-MLR MIL SPEC
 R20F20-2M-ADS-MLR
 R20F20-2M-SN-MLR MIL SPEC

DIMENSIONAL DATA

	R17F13-2M-ADS(SN)-MLR	R13F17-2M-ADS(SN)-MLR	R20F20-2M-ADS(SN)-MLR
Refrigerator Net Capacity (cu ft / ltr)	17 / 481	14 / 396	19.3 / 547
Freezer Net Capacity (cu ft / ltr)	14 / 396	17 / 481	19.3 / 547
Width Overall (in / mm)	48 / 1219	48 / 1219	58 / 1473
Depth Overall (in / mm)	33 / 838	33 / 838	33 / 838
Height Overall (in / mm)	72 / 1829	72 / 1829	72 / 1829
Refrigerator Interior Width (in / mm)	21.5 / 552	18.25 / 464	25 / 635
Refrigerator Interior Depth (in / mm)	26.5 / 673	26.5 / 673	26.5 / 673
Refrigerator Interior Height (in / mm)	50.25 / 1276	50.25 / 1276	50.25 / 1276
Freezer Interior Width (in / mm)	18.5 / 464	21.5 / 552	25 / 635
Freezer Interior Depth (in / mm)	26.5 / 673	26.5 / 673	26.5 / 673
Freezer Interior Height (in / mm)	50.25 / 1276	50.25 / 1276	50.25 / 1276
Depth Over Body (in / mm)	30 / 762	30 / 762	30 / 762
OA Depth with Door Open 90° (in / mm)	54.5 / 1384	54.5 / 1384	58 / 1473
Refrigerator Clear Door Width (in / mm)	20.5 / 527	20.5 / 527	24 / 610
Freezer Clear Door Width (in / mm)	17.25 / 438	17.25 / 438	24 / 610
Refrigerator Clear Full Door Height (in / mm)	48.25 / 1226	48.25 / 1226	48.25 / 1226
Freezer Clear Door Width (in / mm)	48.25 / 1226	48.25 / 1226	48.25 / 1226
Number of Doors	2	2	2
Refrigerator Number of Shelves	3	3	3
Freezer Number of Shelves	3	3	3
Refrigerator Shelf Area (sq ft / sq m.)	16 / 1	13 / 1	18 / 2
Freezer Shelf Area (sq ft / sq m.)	13 / 1	16 / 1	18 / 2
Weight (lbs / kg)	595 / 268	595 / 268	687 / 309
ELECTRICAL DATA	Ref Fre	Ref Fre	Ref Fre
Voltage / Breaker Amp	115	115	115
RLA Amps / Defrost	6.7 / 6.4/4.1	6.4/4.1 / 6.7	6.7 / 10.5/4.1
REFRIGERATION DATA			
Refrigerator compressor H.P.	1/4	1/4	1/4
Freezer Compressor H.P.	1/3	1/3	1/2
Refrigerator BTU / HR - KCAL / HR	2200 / 554	2200 / 554	2200 / 554
Freezer BTU / HR - KCAL / HR	1980 / 499	1980 / 499	2260 / 570
SHIPPING DATA			
Width-Crated (in/mm)	50 / 1270	50 / 1270	60 / 1524
Depth-Crated (in/mm)	36 / 914	36 / 914	36 / 914
Height-Crated (in/mm)	76 / 1930	76 / 1930	76 / 1930
Weight-Crated (lbs / kg)	685 / 308	685 / 308	777 / 350
Volume -Crated (cu ft / ltr)	79 / 2237	79 / 2237	95 / 2690

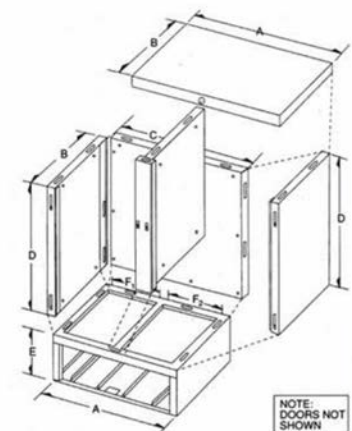
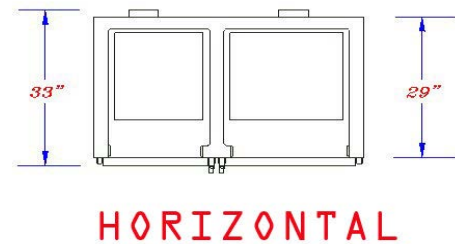
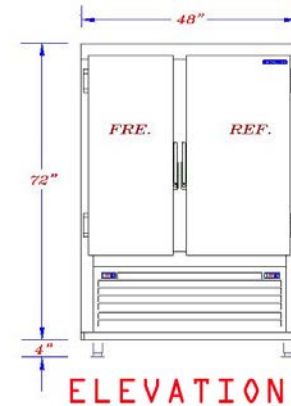

	R17F13	R20F20
"A"	48	58
"B"	29	29
"C"	41	51
"D"	48.5	48.5
"E"	20	20
"F."	18.25	25
"F."	21.75	25

EACH CONDENSING UNIT SHOULD HAVE ITS OWN BREAKER

R17F13-2M-ADS (SN)-MLR



www.cospolich.com

Post Office Box 1206 • Destrehan, Louisiana 70047

Toll Free: 800-423-7761 • Local: 985-725-0222 • FAX: 985-725-1564