

COSPOLICH

2M
SERIES

MODULAR FREEZERS

MODEL NUMBERS:

F50-2M-ADS-MLR

F50-2M-5N-MLR MIL SPEC

Designed for easy installation where passage ways or other obstructions prohibit the use of conventional units.

CABINET CONSTRUCTION

Exterior and interior of all standard cabinets, including front, sides, doors and louvered grill are constructed of heavy gauge, type 304 stainless steel.

Special attention was taken in engineering the doors of the Cospolich cabinet. The door unit was designed to withstand the continuous use and abuse that is common in all food service applications.

Resilient vinyl gaskets which are pre-formed in frames with welded corners, greatly inhibit bacterial growth and are easily replaceable.

Heaters, which are concealed under the thermal breaker strip around the door perimeter, prevent condensation.

INSTALLATION

As an aid to installation, a foundation for securing the cabinet to the deck is an available option. Installation instructions and a manual are furnished with the unit.

HARDWARE

Positive latches with magnetic back-up are included on all standard cabinets to assure positive latching and sealing. Incorporated into the latch is a replaceable, keyed cylinder lock.

Heavy duty, adjustable, chrome plated hinges are provided on all standard cabinets. Also available, at no extra cost, are 180 degrees self-closing, cam-lift hinges with stay-open feature at 93 degrees.

Cabinet body and doors are insulated with foamed-in-place polyurethane foam, providing for excellent rigidity and the best insulating properties in the industry.

REFRIGERATION SYSTEM

All components of the refrigeration system, with the exception of the evaporator, are bottom mounted on a heavy duty base frame behind a louvered grill which is easily removable without the use of tools. The condensing unit is mounted on a slide out rail for ease in cleaning and servicing.

All evaporator coils are copper tube, and all AC voltage models have forced-air ventilation. The refrigerant flow is monitored by an expansion valve for effective cooling. A condensate evaporator is provided, thus eliminating the need for additional plumbing.

Refrigeration lines are fabricated using self-sealing, quick-connect fittings, which allow assembly without recharging system.



F50-2M-ADS-MLR

Temperature of the cabinet is factory adjusted, and the controls, along with off/on switch are located in the condensing unit area.

Defrost cycles on specified low-temperature cabinets (ADS models) prevent the need for manual defrosting.

SHELVING

Standard interior shelving consists of heavy-duty epoxy-coated steel wire with front rail. Each shelf is adjustable in one-inch increments. Stainless steel shelving and brackets are also available.

SERVICE AID

An optional service kit, including spare parts and installation instructions, is available for each model. U.L. and U.S.P.H.

U.L. and U.S.P.H.

This equipment is listed by Underwriters Laboratories, Inc. for safety and sanitation and is built according to standards as set forth by the U.S. Public Health Service.

THIS UNIT AVAILABLE IN OUR STANDARD CONSTRUCTION

FEATURES

- Stainless steel interior and exterior
- Oversized refrigeration system
- Anti-condensate door heaters
- Heavy-duty chrome-plated hardware
- Door with adjustable alignment
- Epoxy coated adjustable shelving with front rail
- Vaporizing pan to remove condensate
- Removable grill
- Polyurethane insulation
- Slide-out condensing unit
- Resilient gaskets
- Exterior dial thermometer
- Quick connect fittings
- Polarized electrical fittings
- Auto Defrost



OPTIONS

Same options available as offered on the standard construction.

THE MODULAR CONCEPT

This series of modular refrigerators was engineered and constructed to solve the problem of replacing existing failed equipment. Unique to the industry, these units, which comprise a series of interlocking components, brought new meaning to the term "hatchable" equipment. This innovative design allows for equipment upgrades without having to cut access ways in decks and bulkheads or having to modify passage ways.

www.cospolich.com

Quality & Innovation Since 1937

MODULAR FREEZERS

MODEL NUMBERS:
F50-2M-ADS-MLR
F50-2M-SN-MLR MIL SPEC

DIMENSIONAL DATA

F50-2M-ADS-MLR (SN MIL SPEC)
115V 220V

Net Capacity (cu ft / ltr)	52.9 / 1498	52.9 / 1498
Width Overall (in / mm)	65 / 1651	65 / 1651
Depth Overall (in / mm)	33 / 838	33 / 838
Height Overall (in / mm)	72 / 1829	72 / 1829
Interior Width (in / mm)	60 / 1524	60 / 1524
Interior Depth (in / mm)	26.5 / 673	26.5 / 673
Interior Height (in / mm)	50.25 / 1276 65.25 / 1657	50.25 / 1276 65.25 / 1657
Depth Over Body (in / mm)	31 / 787	31 / 787
OA Depth with Door Open 90° (in / mm)	62.5 / 1588	62.5 / 1588
Clear Door Width (in / mm)	27.5 / 699	27.5 / 699
Clear Half-Door Height (in / mm)	30.25 / 768	30.25 / 768
Clear Full Door Height (in / mm)	48.25 / 1219	48.25 / 1219
Number of Doors	3	3
Number of Shelves	7	7
Shelf Area (sq ft / sq m.)	49 / 5	49 / 5
Weight (lbs / kg)	840 / 378	840 / 378

ELECTRICAL DATA

Voltage	115	220
Total Amperes	19.6	9.8
Defrost Amperes (Freezer)	9.6	4.8

REFRIGERATION DATA

Compressor H.P.	3/4	3/4
BTU / HR - KCAL / HR	3260 / 822	3260 / 822

SHIPPING DATA

Width-Crated (in / mm)	67 / 172	67 / 172
Depth-Crated (in / mm)	37 / 940	37 / 940
Height-Crated (in / mm)	76 / 1930	76 / 1930
Weight-Crated (lbs / kg)	930 / 419	930 / 419
Volume-Crated (cu ft / ltr)	109 / 3087	109 / 3087



ELEVATION

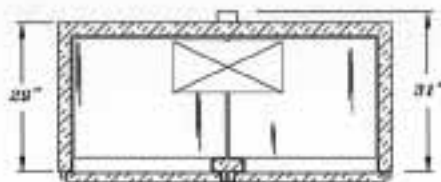

HORIZONTAL SECTION

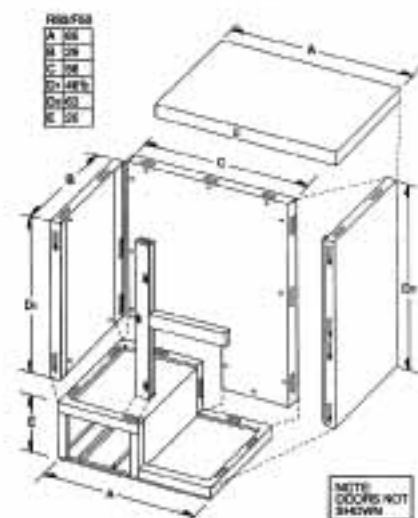

Naval Shipboard Models Available.

COSPOLICH

www.cospolich.com

Post Office Box 1206 • Destrehan, Louisiana 70047
 Toll Free: 800-423-7761 • Local: 985-725-0222 • FAX: 985-725-1564