

# COSPOLICH

## MODEL NUMBERS:

**HFC3T-2M-S-MLR**    **HFC3T-2M-SN-MLR**  
**HFC4T-2M-S-MLR**    **HFC4T-2M-SN-MLR**  
**HFC5T-2M-S-MLR**    **HFC5T-2M-SN-MLR**  
**HFC6T-2M-S-MLR**    **HFC6T-2M-SN-MLR**  
**HFC8T-2M-S-MLR**    **HFC8T-2M-SN-MLR**

## HOT FOOD COUNTERS

### APPLICATION

The superior design of our products encompass quality, user comfort, as well as aesthetics. It is our interest that our Hot Food Counters not only look pleasing, but additionally provide function and service while complimenting the adjoining equipment in the service area.

The warming wells feature individual controls, allowing products to be maintained at the preferred temperatures.

Drains on the individual warming wells are connected to a drain manifold, with individual valves to isolate each well.

Wiring for each well is connected to a common electrical enclosure. The enclosure includes individual circuit breakers and single point grounded connections.

To further support the specific application, Cospolich offers a variety of options to satisfy most every purpose or need. Items such as displays, sneeze shields, tray rails, utensil, bowl and plate dispensers.

### CONSTRUCTION

To compliment our design, we incorporate quality materials assembled by true craftsmen. Our use of heavy gauge type 304 stainless steel throughout inhibits corrosion and provides the best in sanitary conditions. Each well is insulated individually to retain heat. The lower storage can withstand the weight of heavier items or be used to organize smaller ones. If drains are a necessity, all wells can get plumbed into a single outlet.

**PLEASE VISIT OUR WEB SITE TO VIEW  
MANY OTHER PRODUCTS**



**HFC3T-2M-S-MLR**

*Designed for easy installation where passage ways or other obstructions prohibit the use of conventional units.*

## THIS UNIT AVAILABLE IN OUR CONVENTIONAL CONSTRUCTION

### OPTIONS

- One or two tier upper display
- Single or double sided sneeze shield
- Single or double sided tray slides (fixed or folding)
- Stainless Steel doors, in-fitting or sliding
- Stainless Steel shelving
- Soup wells
- Utensil dispensers
- Plate dispensers
- Heavy-duty, Stainless Steel, adjustable legs
- Casters
- Special dimensions
- Voltages (120V, 208/230V)

### FEATURES

- Type 304 Stainless Steel
- Insulated hot wells
- Individually thermostatically controlled hot wells
- Lower Storage
- Drains with valves

**CONTACT FACTORY  
FOR YOUR  
SPECIFIC CAPACITY  
REQUIREMENTS**

[www.cospolich.com](http://www.cospolich.com)

**2M  
SERIES**

**Quality & Innovation Since 1937**

# MODULAR HOT FOOD COUNTERS

## MODEL NUMBERS:

**HFC3T-2M-S-MLR**    **HFC3T-2M-SN-MLR**  
**HFC4T-2M-S-MLR**    **HFC4T-2M-SN-MLR**  
**HFC5T-2M-S-MLR**    **HFC5T-2M-SN-MLR**  
**HFC6T-2M-S-MLR**    **HFC6T-2M-SN-MLR**  
**HFC8T-2M-S-MLR**    **HFC8T-2M-SN-MLR**

### DIMENSIONAL DATA

	HFC3T-2M-S-MLR	HFC4T-2M-S-MLR	HFC5T-2M-S-MLR	HFC6T-2M-S-MLR	HFC8T-2M-S-MLR
Net Capacity (cu ft / cu ltr)	13.5 / 382	30 / 850	35.2 / 997	40.6 / 1150	49.7 / 1407
Width Overall (in / mm)	54 / 1372	66 / 1676	78 / 1981	90 / 2286	110 / 2794
Depth Overall (in / mm)	26 / 660	26 / 660	26 / 660	26 / 660	26 / 660
Height Overall (in / mm)	30 / 762	30 / 762	30 / 762	30 / 762	30 / 762
Number of Wells	3	4	5	6	8
Number of Doors	2	2	3	3	3
Weight (lbs / kg)	246 / 111	304 / 137	342 / 154	409 / 184	545 / 245
<b>ELECTRICAL DATA</b>					
Voltage	115 / 220	115 / 220	115 / 220	115 / 220	115 / 220
Total Amperes (per well)	12.5 / 6.7	12.5 / 6.7	12.5 / 6.7	12.5 / 6.7	12.5 / 6.7
Total Wattage (per well)	1500 / 1600	1500 / 1600	1500 / 1600	1500 / 1600	1500 / 1600
<b>SHIPPING DATA</b>					
Width-Crated (in / mm)	56 / 1422	68 / 1727	80 / 2032	92 / 2337	112 / 2845
Depth-Crated (in / mm)	28.5 / 724	28.5 / 724	28.5 / 724	28.5 / 724	28.5 / 724
Height-Crated (in / mm)	34 / 864	34 / 864	34 / 864	34 / 864	34 / 864
Weight-Crated (lbs / kg)	389 / 175	480 / 216	540 / 243	646 / 291	861 / 387
Volume-Crated (cu ft / ltr)	42 / 1189	51 / 1444	60 / 1699	70 / 1982	85 / 2407

[www.cospolich.com](http://www.cospolich.com)

MODEL SHOWN:

**HFC3T-2M-S-MLR**

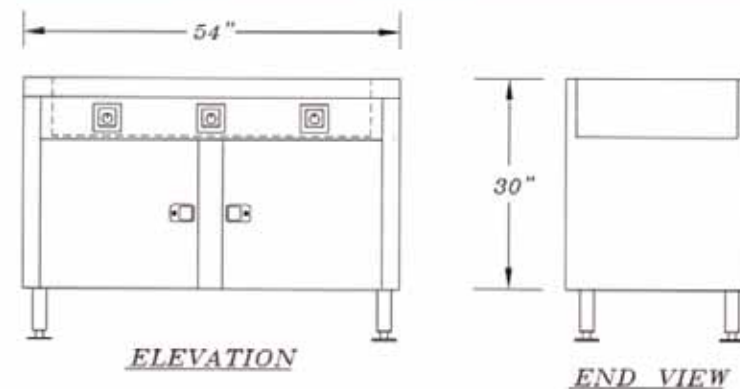

← **3 WELL COUNTER WITH OPEN BASE AND CUSTOM SNEEZE SHIELD**



**STANDARD COSPOLICH RHN-N HOT WELL** →



**Naval Shipboard Models Available.**

# COSPOLICH

Post Office Box 1206 • Destrehan, Louisiana 70047

Toll Free: 800-423-7761 • Local: 985-725-0222 • FAX: 985-725-1564